



RS-232 TO RS-422 / RS-422 TO RS-232 CONVERTER

PRODUCT P/N: 930510

INSTALLATION MANUAL

REV B

Shadin Avionics
6831 Oxford Street
St. Louis Park, MN 55426
USA

Sales: (800)-328-0584
Technical Support: (800)-388-2849
WWW.SHADIN.COM

MANUAL P/N: IM0510

INSTALLATION MANUAL
RS-232 TO RS-422 / RS-422 TO RS-232 CONVERTER

Rev: B

P/N 930510

Page: i of ii

PAGE CONTROL CHART

<u>SECTION NO.</u>	<u>DESCRIPTION</u>	<u>PAGE</u>	
1.	OVERVIEW	1-1	
	1.1 The Manual	1-1	
	1.2 Product Description	1-1	
	1.3 Specifications	1-2	
	1.4 Inputs	1-3	
	1.5 Outputs	1-3	
2.	INSTALLATION PROCEDURE	2-1	
	2.1 Approval for installation	2-1	
	2.2 Mounting	2-1	
	2.3 Electrical Connections	2-1	
3.	ENVIRONMENTAL QUALIFICATION FORM	3-1	
	Environmental Qualification Form (Cont.)	3-2	
4.	INSTALLATION DRAWINGS AND INSTALL KIT PARTS LIST		
<u>Drawing No.</u>	<u>Description/ Part Number</u>	<u>DATE</u>	<u>REV</u>
4005-574	Installation, RS-232 to RS-422 / RS-422 to RS-232 Converter, P/N 930510	1-12-98	A
N/A	Parts List, Install Kit for 15 pins D-Sub P/N IK9337	1-11-06	F

INSTALLATION MANUAL
RS-232 TO RS-422 / RS-422 TO RS-232 CONVERTER

Rev: B

P/N 930510

Page: ii of ii

REVISION LOG

REV.	DATE	APP'D	CHANGE
-	03/27/02	ZK	Baseline Release
A	11/07/02	RRR	Added MTBF to Specifications page
B	7-12-66	CS	Changed Company Name & Sect. 2.1

The information in this manual is subject to change without notification. To ensure complete and current updates, note the Revision Log above and call Technical Assistance for updated information.

INSTALLATION MANUAL

RS-232 TO RS-422 / RS-422 TO RS-232 CONVERTER

Rev: B

P/N 930510

Page: 1-1

1. OVERVIEW

1.1 THE MANUAL

This manual is intended to determine a proper installation of the RS-232 to RS-422 / RS-422 to RS-232 Converter. Installation instructions should be read and followed.

1.2 PRODUCT DESCRIPTION

The purpose of the RS-232 to RS-422/RS-422 to RS-232 Converter is to take serial data in either RS-232 or RS-422 format and convert it to the other format. This converter accepts any serial data format and converts data simultaneously as bi-directional level translator with two independent converter channels.

The system diagram is given in Figure 1.

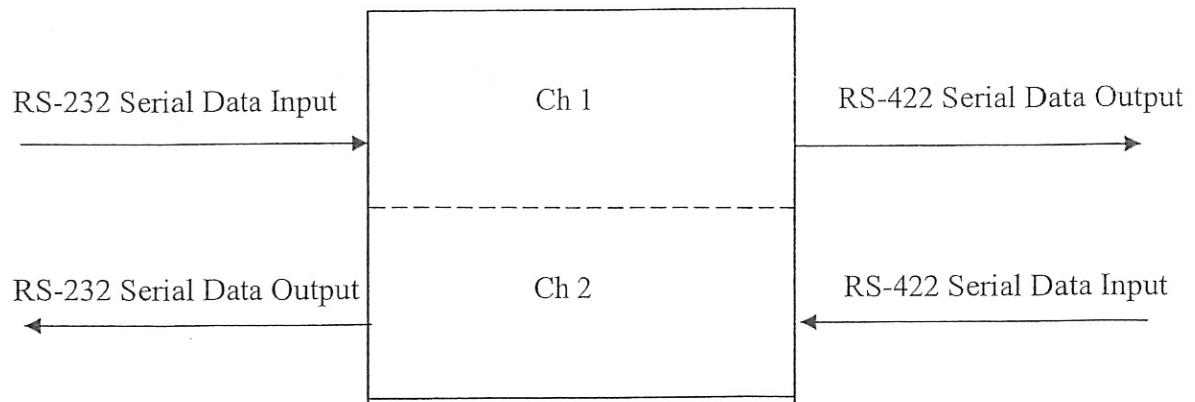

Figure 1: P/N 930510, RS-232 to RS-422/RS-422 to RS-232 Converter

LED 4	LED 3	LED 2	LED 5	LED 1
Yellow	Yellow	Yellow	Green	Red
TX RS-422 (+)	TX RS-422 (-)	TX RS-232	RX RS-232	Power ON

When LED 1 is illuminated power is "ON".

When LED 2-5 are illuminated, RS-232/RS-422 lines are active.

INSTALLATION MANUAL
RS-232 TO RS-422 / RS-422 TO RS-232 CONVERTER

Rev: B

P/N 930510

Page: 1-2

1.3 SPECIFICATIONS

Physical Specifications

Dimensions: 1.15H x 4.30L x 2.40W (inches)
 Weight: 0.4 lbs.

Electrical and Functional

Power Supply Voltage: +28VDC
 Supply Current: 30mA at 28VDC
 Protection: Not internally fused
Inputs: *Serial Data: RS-232 or RS-422*
Outputs: *Serial Data: RS-232 or RS-422*

Environmental

RTCA/DO-160C
 Categories: F1XAXM,NXXXXXXXXZBXXXXBXXX
 Operating Temperature: -20° to +55°C
 Operating Altitude: Up to 55,000 ft
 Storage Temperature: -55° to +85°C
 In-Flight loss of Cooling: Equipment can run indefinitely with no cooling
 Certification: TSO - C44b
 MIL-HDBK-217 MTBF 135,800 Hours

INSTALLATION MANUAL
RS-232 TO RS-422 / RS-422 TO RS-232 CONVERTER

Rev: B

P/N 930510

Page: 1-3

1.4 INPUTS

This section specifies the interfaces for the Shadin RS-232 to RS-422/RS-422 to RS-232 Converter.

- RX RS-232 Serial Data
- RX RS-422 Serial Data

1.5 OUTPUTS

- TX RS-232 Output Serial Data
- TX RS-422 Output Serial Data

INSTALLATION MANUAL

RS-232 TO RS-422 / RS-422 TO RS-232 CONVERTER

Rev: B

P/N 930510

Page: 2-1

2. INSTALLATION PROCEDURE

2.1 APPROVAL FOR INSTALLATION

The conditions and tests required for TSO approval of this article are minimum performance standards. It is the responsibility of those installing this article either on or within a specific type or class of aircraft to determine that the aircraft installation conditions are within the TSO standards. TSO articles must have separate approval for installation in an aircraft. The article may be installed only if performed under 14 CFR part 43 or the applicable airworthiness requirements.

All work must conform to AC 43.13-1B.

2.2 MOUNTING

The RS-232 to RS-422/RS-422 to RS-232 Converter (P/N 930510) should be mounted in a dry location and the equipment may be installed in a temperature controlled, non-pressurized location.

Use installation drawing, Drawing No.: 4005-574, to connect the RS-232 to RS-422/RS-422 to RS-232 Converter to the system. For mounting use # 6-32 screws.

2.3 ELECTRICAL CONNECTIONS

Connection to Power Supply +28 VDC

930510		Description
J1:1	To	+14 to +28 VDC Power
J1:2, 7, 8, 9, 10, 13, 14, 15	To	GND

Inputs

930510		Description
J1:3	To	RX RS-422 (+)
J1:4	To	RX RS-422(-)
J1:5	To	RX RS-232

Outputs

930510		Description
J1:6	To	TX RS-232
J1:11	To	TX-RS-422 (+)
J1:12	To	TX RS-422 (-)

INSTALLATION MANUAL
RS-232 TO RS-422 / RS-422 TO RS-232 CONVERTER

Rev: B

P/N 930510

Page: 3-1

3.0 ENVIRONMENTAL QUALIFICATION FORM

NOMENCLATURE: RS-232 to RS-422 / RS-422 to RS-232 CONVERTER

TYPE/MODEL/PART NO: 930510 **TSO NUMBER: C44b**

MANUFACTURER'S SPECIFICATION AND/OR OTHER APPLICABLE SPECIFICATION:

Report 4005K, RTCA/DO-160C

MANUFACTURER: Shadin Avionics

ADDRESS: 6831 Oxford Street, St. Louis Park, Minnesota 55426-4412

<u>CONDITIONS</u>	<u>SECTION</u>	<u>DESCRIPTION OF TESTS CONDUCTED</u>
Temperature and Altitude	4.0	Tested to Category F1.
Low Temperature		Low Operating Temperature of -30°C.
High Temperature		
Altitude		
Decompression		
Overpressure		
Temperature Variation	5.0	Identified as Category X. Not tested.
Humidity	6.0	Tested to Category A.
Operational Shock and Crash Safety	7.0	Identified as Category X. Not tested.
Vibration	8.0	Tested to Category M, N
Explosion	9.0	Identified as Category X. Not tested.
Waterproofness	10.0	Identified as Category X. Not tested.
Fluids Susceptibility	11.0	Identified as Category X. Not tested.

INSTALLATION MANUAL
RS-232 TO RS-422 / RS-422 TO RS-232 CONVERTER

Rev: B

P/N 930510

Page: 3-2

ENVIRONMENTAL QUALIFICATION FORM (Cont.)

<u>CONDITIONS</u>	<u>SECTION</u>	<u>DESCRIPTION OF TESTS CONDUCTED</u>
Sand and Dust	12.0	Identified as Category X. Not tested.
Fungus	13.0	Identified as Category X. Not tested.
Salt Spray	14.0	Identified as Category X. Not tested.
Magnetic Effect	15.0	Tested to Category Z.
Power Input	16.0	Tested to Category B. Paragraph 16.5.2.1 only.
Voltage Spike	17.0	Identified as Category X. Not tested.
Audio Frequency Susceptibility	18.0	Identified as Category X. Not tested.
Induced Signal Susceptibility	19.0	Identified as Category X. Not tested.
Radio Frequency Susceptibility	20.0	Identified as Category X. Not tested.
Radio Frequency Emission	21.0	Tested to Category B.
Lightning Induced Transient Susceptibility	22.0	Identified as Category X. Not tested.
Lightning Direct Effects	23.0	Identified as Category X. Not tested.
Icing	24.0	Identified as Category X. Not tested.

INSTALLATION MANUAL
RS-232 TO RS-422 / RS-422 TO RS-232 CONVERTER
P/N 930510

SECTION 4.0

**INSTALLATION DRAWINGS AND
INSTALL KIT PARTS LISTS**

The following drawings are arranged in the sequence specified on page i of the Page Control Chart.

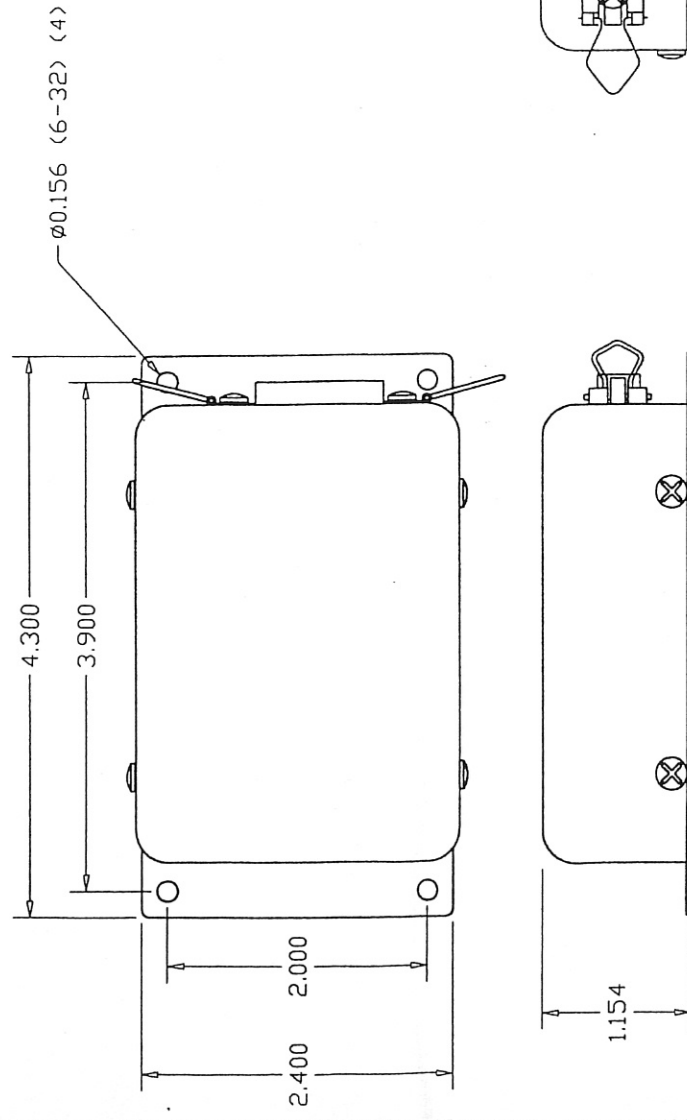

MATING CONNECTOR:
 CINCH # DA-15S
 HOOD = CINCH # DA19771-1
 BAIL CLIPS, (2), SHADIN P/N 230019H-1, SUPPLIED

CONNECTOR WIRING

- 1.- +12 TO +28V DC
- 2.- GND
- 3.- RX+ RS-422
- 4.- RX- RS-422
- 5.- RX RS-232
- 6.- TX RS-232
- 7.- GND
- 8.- GND
- 9.- POWER GND
- 10.- GND
- 11.- TX+ RS-422
- 12.- TX- RS-422
- 13.- GND
- 14.- GND
- 15.- GND

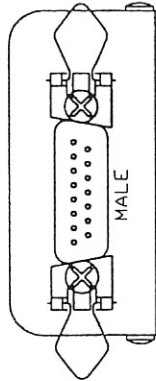

9801/006	A	1-2-98	DMD	TFC	CORRECTED TITLEBLOCK
9501/02	-	1/4/95	DAP	SES	BASELINE RELEASE
ECO #	REV.	DATE	BY	APP'D	DESCRIPTION
SCALE: FULL					
UNLESS OTHERWISE NOTED DIMENSIONS ARE IN INCHES		DRAWING DATE 11/21/94		SHADIN CO., INC. MINNEAPOLIS, MN 55426	
TOLERANCES: .XX = ±0.1		DRAFTER DAP		INSTALLATION DWG, CONV,	
.XXX = ±0.01		APPROVED SES		RS-232 TO 422 OR	
X.XXX = ±0.005		FILE NAME 930510A.DWG		RS-422 TO 232	
FINISH N/A	MATERIAL N/A	DIRECTORY 930510-0	DRAWING NO. 4005-574		
DRAWING NO. 4005-574			SIZE A	P/N 930510	REV A
DRAWING NO. 4005-574			SIZE A	P/N 930510	REV A

Report: 4037
ECO Date: January 11, 2006
Rev: F
Sec.: IX
Page 1 of 1

ECO # 0601/013
Release date: 1-11-06
Approved: *LB*

Part #: IK9337
Description: INSTALL KIT FOR 15PIN D-SUB

PARTS LIST

Drawing #: N/A

FN	P/N	QTY.	DESCRIPTION	MFG.	MFG.#	DESIGNATION	COMMENTS
5	230019H-1	2	SPRING LATCH CLIP	SHA	4028-074		*
10	230050C	1	CONN, 15 Pin D-Sub F Crimp w/contacts	POS	M24308/2-2 (RD15F10000-50)		
15	230038	1	CONN HOOD, 15 Pin D-Sub	CIN	DA-24658		
20	511002	2	SCREW, 4-40 x 1/4 Phil Pan HD SS	MCM	91772A106		
25	512007	2	NUT, 4-40 3/16 x 1/16 SS	AFT	HNSP188 04C000		
27	512101	2	RETAINER CLIP, "Bow-Tie" Style	KEY	2061K		*
30	541001	2	WASHER, #4 Split Lock, SS	MCM	92147A005		
32	753217	1	COMPUTER LABEL, 3.5"x 15/16"	AVR	4013		
35	PK1001	1	BAG, 2.5 x 3, 4 MIL Zip Lock				
45	PK1007	1	BAG, 6 x 8, 4 MIL				

15 items

* Use FN 5 Or FN 27, Not Both - Depending On D-Sub Connector Style Used.